

Tomato plant disease detection and pesticide suggestion using Convolution Neural Network

Aishwarya Soni¹, Rana Shaikh², Komalika Sonawane³, Simran Mascarenhas⁴

^{1,2,3,4} Department of Computer, AISSMS Institute of Information Technology, Maharashtra, India

Corresponding Author: Aishwarya Soni (aishusoni3777@gmail.com)

Article Information

ABSTRACT

Article history:

Received March 9, 2023

Revised June 12, 2023

Accepted June 19, 2023



Tomatoes are among the most essential crops with a substantial market value that get grown in huge amounts. They are widely grown and consumed not only in India but also all around the world. The main factor influencing this crop's production quality and quantity is disease. In previous studies, only the leaves of the plant were considered to identify diseases but, in some diseases, it's only the fruit that gets affected while the other parts of the plant just look fine. Identifying the disease with the naked eye sometimes leads to an inaccurate prediction, resulting in applying the wrong pesticide, which might spoil the plant. The unavailability of experts in many of the locations makes it difficult for the farmers to identify the disease. Despite experts being available in some regions, it's a time and cost-consuming process. Detecting the diseases earlier would reduce their effect on plants and raise crop productivity. Therefore, it is crucial to correctly diagnose these diseases and apply the right pesticide. An automated system can be used to solve these problems. To address this issue, we have come up with a system that uses a convolutional neural network (CNN) to identify the disease and suggests a pesticide to help eliminate that disease. This system implements a CNN since it provides the highest level of accuracy.

KEYWORDS: Convolutional neural network, feature extraction, pesticide suggestion, disease detection.

1. INTRODUCTION

Agriculture is a livelihood for a majority of the population in countries like India. Every nation's economy depends on agriculture. Over the years, technology has proved to be extremely useful in the agricultural sector and will continue to be so. The fundamental goal of agricultural advancement is to satisfy the expanding population's demand. To thrive in the current climate, agriculture needs to be upgraded. Both fungal and bacterial infections can harm crops. The productivity of farmers is severely harmed by this. Crops should be in good health for the best yield. Disease detection through visual examination will always be challenging. To achieve this, the farm must be constantly watched. This technique is time-consuming. When the farm is large, this can be very expensive as well. Owing to this complexity, even agricultural professionals struggle to identify the diseases and come up with a fix. The farmers would benefit significantly from an automated system that could detect plant diseases. The farmers may use this system as a tool to alert them at the appropriate time and take the necessary precautions.

Plant parts including leaves, fruits, seeds, etc. can be affected by a variety of diseases that impact the plant. Certain plant segments involved are more susceptible to these diseases. The most significant component of a plant is its leaves. If a plant's leaf gets infected, it will directly disrupt the life cycle of that plant. Bacterial illnesses, fungal diseases, and other conditions are frequently seen in leaves. Thus, it is important to find plant diseases early.

2. REVIEW OF RELATED WORK

In paper [1], the authors have implemented a method for detecting the disease using a deep-learning method. Google Net and VGG16 CNN-based models were employed to classify tomato leaf disease. VGG16 achieved an accuracy rate of 98.00%, while Google Net achieved a higher accuracy rate of 99.23%. The plant village dataset is used to identify the diseases containing 10735 images.

They have identified the disease on the leaf images for Tomato. Evaluated the performance of the two models by calculating different performance evaluation metrics like TP, TN, FN, and ACC.

In the paper [2], the authors explained how deep learning is being used to recognize plant diseases, which has greatly improved the recognition accuracy of image classification and object detection systems. They provided a detailed analysis of recent research on the use of deep learning to identify plant leaf diseases. To improve the precision of classification, huge datasets with high variability are collected, transfer learning is performed, data is augmented, and CNN activation maps are visualized, as well as the importance of hyperspectral technologies for detecting the disease.

In the paper [3], the authors discussed machine-learning techniques for detecting leaf disease. The identification of diseases involves the use of a supervised machine learning algorithm i.e., the Support Vector Machine (SVM) algorithm. the methodology used in detecting the diseases which involves the basic steps like taking input image, then image pre-processing after pre-processing extracting the useful features which are crucial in the classification of the image, training the model using the infected image and healthy images followed by clustering and classification.

The proposed system in the paper [4] uses The Internet of Things (IoT) to detect disease. The system effectively identifies the disease and uses features and segments from the SVM result robot to spray the already-defined pesticides. All of the experiments conducted in this study utilized a rose leaf afflicted with bacterial disease. The system captures images of the diseases using the Camera module which is designed to interface with the Raspberry Pi module.

The components used are Raspberry Pi 3 Model, Sprinkler motor, Ultrasonic sensor, electrical relay, motor drive, OpenCV, and L293 Module.

The paper [5], presents a system for disease classification using a combination of Convolutional Neural Network (CNN) and Learning Vector Quantization (LVQ) algorithm. The system was tested on a dataset consisting of 400 training images and 100 test tomato leaf images, and it was able to classify the data into a predetermined number of classes. It is suitable for solving minor problems.

Paper [6] is research on various plant leaf disease detection techniques using leaf Images. Here, the authors have presented different plant disease detection techniques They have given a tabular analysis of several identification, segmentation, and classification algorithms based on diverse datasets, with their advantages, disadvantages, and accuracy. Perceiving essential features without the need for human interference deviating from its models is the benefit of a Multilayered Convolutional Neural Network.

In a research paper by reference [7], the authors conducted an analysis of various convolutional neural network (CNN) architectures specifically for the classification of tomato leaf diseases. They have used the PlantVillage dataset for evaluation This dataset comprises 14529 images of both healthy and diseased leaves of tomatoes divided into 10 different

classifications. 2905 images were used for testing and 11623 images were considered for training out of the 14529 images. The paper focuses on categorizing tomato leaf diseases using several CNN models. Alex Net, VGG16, Google Net, ResNet-101, and DenseNet-121 were the models utilized. They concluded that all the models worked well, although DenseNet-121 had the highest accuracy and was the smallest of the models. They said that the study can further be expanded to detect and identify diseases, as well as work on developing a mobile-friendly, lightweight model. To boost the performance, the dataset can be improved.

3. CONVOLUTIONAL NEURAL NETWORK

Convolutional neural networks, or CNNs, are network architectures for deep learning. They can consist of multiple layers, sometimes reaching tens or even hundreds of layers as shown in Fig. 1. Each layer within a CNN is designed to learn and detect distinct features or patterns in an image. In the training process of convolutional neural networks (CNNs), various resolution filters are applied to each input image. The resulting convolved images are then passed as input to subsequent layers. These filters initially detect basic features such as brightness and edges and progressively learn more complex features that help in uniquely defining the objects being classified. Tasks like scene categorization, object recognition, segmentation, and image processing can be taught to a CNN. CNN consists of four components:

3.1. Convolutional

Convolution is a fundamental operation in image processing and computer vision that allows the extraction of local features from an image. In other words, the network learns specific patterns within the image and becomes capable of recognizing them universally. Convolution is an element-by-element multiplication. The process involves scanning a section of the image, typically with a size of 3×3 , and performing a convolution operation by multiplying it with a filter as shown in Fig. 2. A feature map is the outcome of element-wise multiplication. This step is repeated until all the images are scanned. The image is reduced in size after convolution.

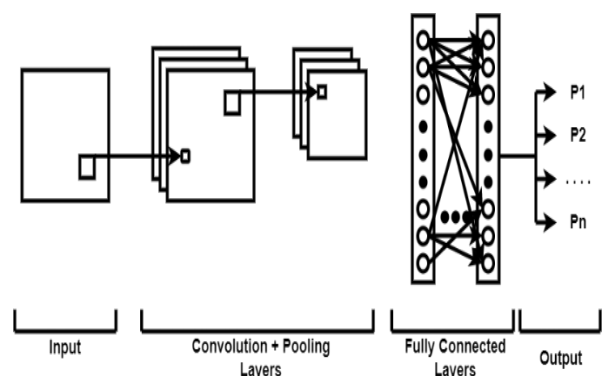

Fig. 1. A general CNN architecture

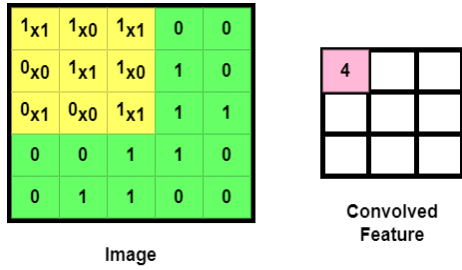

Fig. 2. Convolution on 5x5 image and 3x3 filter

3.2. Non-Linearity (ReLU)

An activation function is applied to the output after the convolution procedure to accommodate for non-linearity. The Relu is the typical convent activation function. Any pixels with negative values are substituted with zero.

3.3. Pooling Operation

The purpose of pooling in convolutional neural networks is to decrease the spatial dimensionality of the input image. The steps are taken to decrease the computational complexity of the operation. By decreasing the dimensionality, the neural network has fewer weights to calculate, thereby reducing the likelihood of overfitting. In the current stage, it is necessary to define both the size and the stride. Using the feature map's maximum value is a typical method of pooling the input image.

3.4. Fully Connected Layers

The final stage involves constructing a conventional artificial neural network. Connecting all the neurons of the previous layer to the next layer is a common method used in neural networks for image classification tasks. The soft-max activation function is often applied to enable the network to classify input images.

4. PROPOSED SYSTEM

This system focuses on using a convolutional neural network to identify and classify diseases. This model will be deployed as a web application.

The dataset utilized in this study consists of a total of 1386 images, encompassing both tomato leaf and fruit images. A total of 13 categories are given in the model, 10 of which are based on tomato leaves, and 3 are based on the fruit. Images of tomato leaves are extracted from the Plant Village dataset and tomato fruits are collected from the internet. Images belonging to the healthy category are 148 including tomato leaves and fruit.

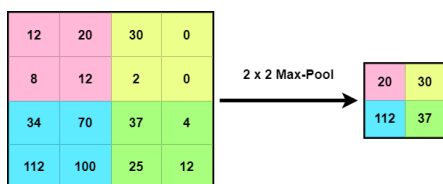

Fig. 3. 2x2 Max pooling

The dataset used for training and testing the models consisted of 1240 images for training and 146 images for testing. Few samples are shown in Fig. 4. The images were in JPG format and had a size of 224x224 pixels in terms of width and height.

The framework comprises multiple stages to improve the accuracy of disease identification, as illustrated in the image. Our system operates as follows and shown in Fig. 5.

Step 1: Image preprocessing steps are performed on the dataset. The dataset will be preprocessed involving image rescaling, reshaping, and array format conversion. Resizing images to match the input size of a convolutional neural network (CNN) is a common preprocessing step in image classification tasks.

Step 2: The next step involves constructing a CNN model, which is preceded by data preprocessing. CNN is fed the training dataset, and the weights are modified to accurately identify the disease and distinguish one from the other. CNN aims to extract an optimal set of features such as color, shape, and texture from the pixel information from an image collected using convolutions.

Step 3: After training the model, the fully connected layer performs the task of classification to predict the disease based on the features obtained by the preceding layers and their respective filters.

Step 4: Pesticides will be recommended, followed by a list of the locations of the pesticide sellers.

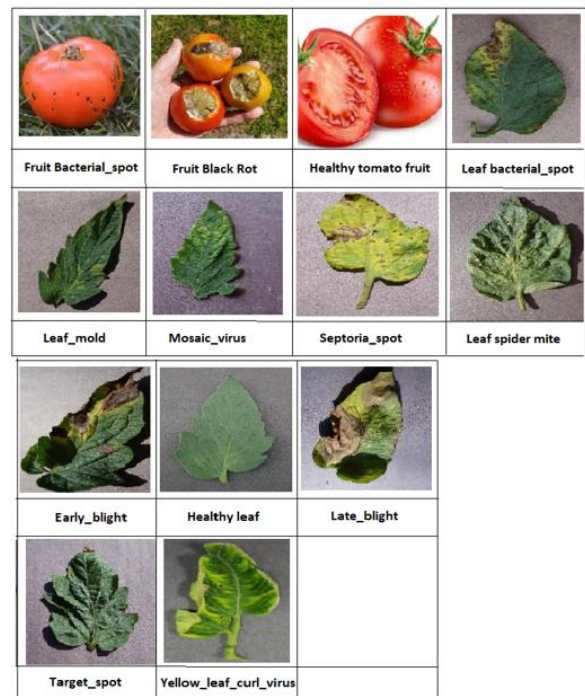

Fig. 4. Class wise sample image of the dataset

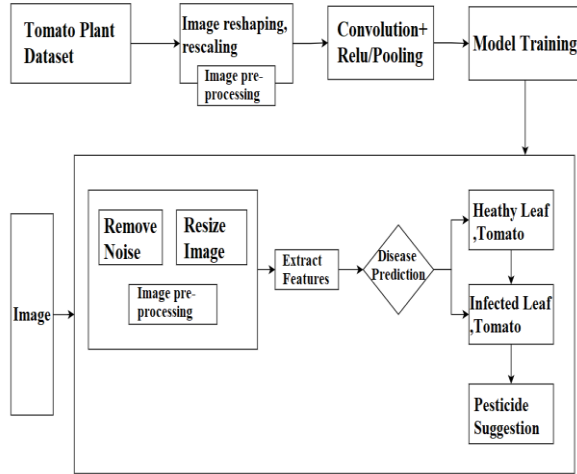

Fig. 5. System Architecture

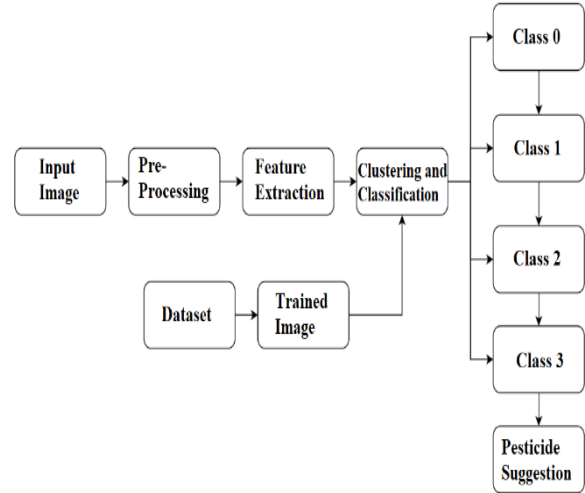

Fig. 6. Class Diagram

5. METHODOLOGY

The proposed methodology detects tomato plant diseases as shown in Fig 6. The classification of whether a leaf or plant is infected with a disease is done by considering the images of a leaf, using image processing techniques, feature extraction, and lastly model development. Once the model is trained, it is evaluated on a separate set of images to ensure its accuracy and reliability.

5.1. Dataset Collection:

The data set utilized for training was gathered from the software and comprised pictures of both healthy leaves and plants with various illnesses. The dataset used in the experiment consists of 1386 images, comprising both tomato leaves and tomato fruit.

5.2. Dataset Pre-processing:

The pre-processing method is used to minimize noise and improve image characteristics. Contrast enhancement is applied before processing the images. By translating input intensity to a new value, it enhances visual characteristics.

5.3. Model Building:

During the training process, pre-processed images are fed into the CNN model to classify various plant diseases.

5.4. Feature extraction:

The classification of images depends on this phase. We only extract features from the affected area rather than choosing the entire image. In the image processing technique, feature extraction is a crucial phase that offers an appropriate platform and the most beneficial constraints. Examining the attributes of a leaf image, such as shape, color, pattern, and size, efficiently is crucial in feature extraction.

5.5. Categorization:

The model is ready to classify unlabeled data of plants, after the training process. The image is fed into the

model, and the training and testing images are compared. The output of the model includes the name of the plant, the disease identified, and the suggested pesticide.

6. RESULTS

The hyperparameters used in this system are given in Table 1. As shown in the Fig. 7 and Fig. 8, the highest accuracy of 99% was obtained after 10 epochs of training and almost 90% of validation accuracy was achieved.

Table 1. Hyperparameters used in the Proposed Model

Hyperparameter	Specification
Count of the convolution layer	3
Count of the max pooling layer	3
Dropout rate	0.5
Activation function	Relu
No. of epoch	5
Batch size	16

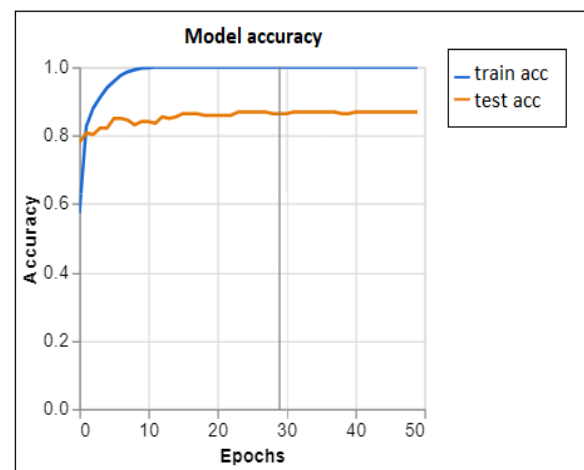

Fig. 7. Model Accuracy

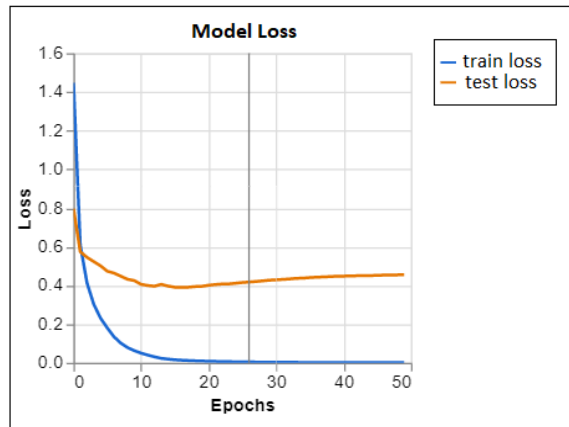

Fig. 8. Model loss

7. CONCLUSION

The agricultural sector is a very important sector that greatly impacts the society. It is not only a necessity but also important for the economy of the country. Tomato being an important crop must be grown with utmost care. Sometimes the fruits of the plant are affected with no visible damage to the leaves. Naked eye observations can be inaccurate and can lead to using the wrong remedies. Seeking help from an expert can be costly as well as time-consuming. Convolution Neural Networks are best suited for image recognition due to their accuracy. Hence, we have used it to make this tool that will help lessen the time and cost consumed during manual prediction. It provides remarkable accuracy in identifying 13 diseases. It classifies diseases based on the fruit along with the leaves as sometimes only the fruit is damaged. It along with predicting the disease, suggests the name of the pesticide that can be used as a remedy.

REFERENCES

- [1] Hareem Kibriya, Rimsha Rafique, Wakeel Ahmad, S.M Adnan, Tomato Leaf Disease Detection Using Convolution Neural Network, 2021 IEEE, DOI: 10.1109/IBCAST51254.2021.9393311.
- [2] Lili Li, Shujuan Zhang, Bin Wang, Plant Disease Detection and Classification by Deep Learning-A Review, IEEE Access (Volume: 9) 2021, DOI: 10.1109/ACCESS.2021.3069646.
- [3] Deepa, Rashmi N, Chinmai Shetty, A Machine Learning Technique for Identification of Plant Diseases in Leaves, 2021 6th International Conference on Inventive Computation Technologies (ICICT), DOI: 10.1109/ICICT50816.2021.9358797.
- [4] JT Dharanika, S Ruban Karthik, S Sabhariesh Vel, S Vyaas, S Yogeshwaran, Automatic Leaf Disease Identification and Fertilizer Agrobot, 2021 7th International Conference on Advanced Computing and Communication Systems (ICACCS), DOI: 10.1109/ICACCS51430.2021.9441993.
- [5] Melike Sardogan, Adem Tuncer, Yunus Ozen, Plant Leaf Disease Detection and Classification Based on CNN with LVQ Algorithm, 2018 3rd International Conference on Computer Science and Engineering (UBMK), DOI: 10.1109/UBMK.2018.8566635.
- [6] Sakshi Raina, Dr. Abhishek Gupta, A Study on Various Techniques for Plant Leaf Disease Detection Using Leaf Image, 2021 International Conference on Artificial Intelligence and Smart Systems (ICAIS), DOI: 10.1109/ICA IS50930.2021.9396023.
- [7] Garima Shrestha, Deepsikha, Majolica Das, Plant Disease Detection Using CNN, Proceedings of 2020 IEEE Applied Signal Processing Conference (ASPCON).
- [8] K. Saraswathi, Detection of Plant Leaf Disease using Image Processing Approach, May 2021 IJSDR, Volume 6 Issue 5.
- [9] Mamta Gehlot, Madan Lal Saini, Analysis of Different CNN Architectures For Tomato Leaf Disease Classification, 5th IEEE International Conference on Recent Advances and Innovations in Engineering (ICRAIE) 2020, DOI: 10.1109/ICRAIE51050.2020.9358279
- [10] Ajra, Mst. Khairun Nahar, Lipika Sarkar, Md. Shohidul Islam, Disease Detection of Plant Leaf using Image Processing and CNN with Preventive Measures, 2020 Emerging Technology in Computing, Communication and Electronics (ETCCE), DOI: 10.1109 / ETCCE 51779 .2020 .9350890.